

FLIR Systems

Thermal Security Cameras

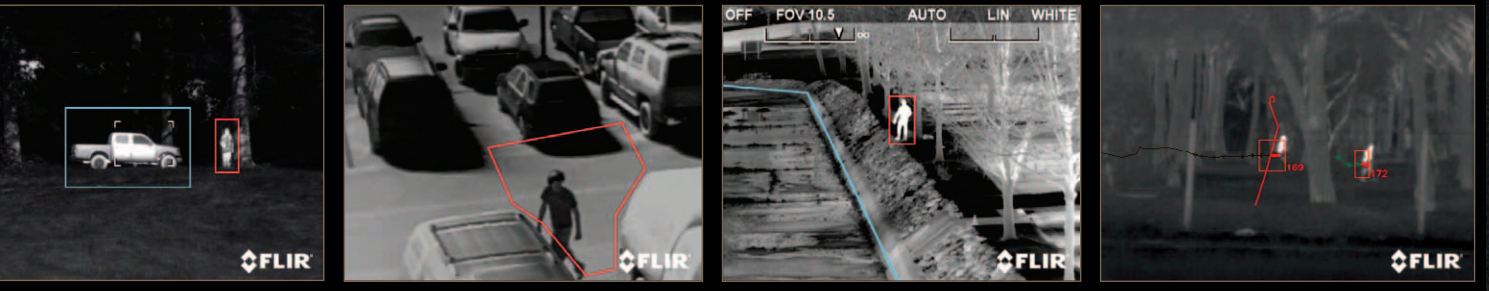

The next level of security.

 **FLIR**[®]

The Power of FLIR Thermal Imagers

Thermal imaging complements and completes your security camera network by turning night into day, and giving you the power to see threats invisible to the naked eye.

Thermal security cameras see heat

Thermal security cameras make pictures from heat energy that is invisible to the naked eye. Everything in the color image below is giving off heat – even the ice cubes she is holding in her left hand, and the circle she traced on the wall with her right hand.



Maximize Detection

In most cases, thermal energy travels through the atmosphere more effectively than visible light. As a result, thermal imagers can see activity at extreme ranges, while visible cameras, which rely on color contrast, fail.

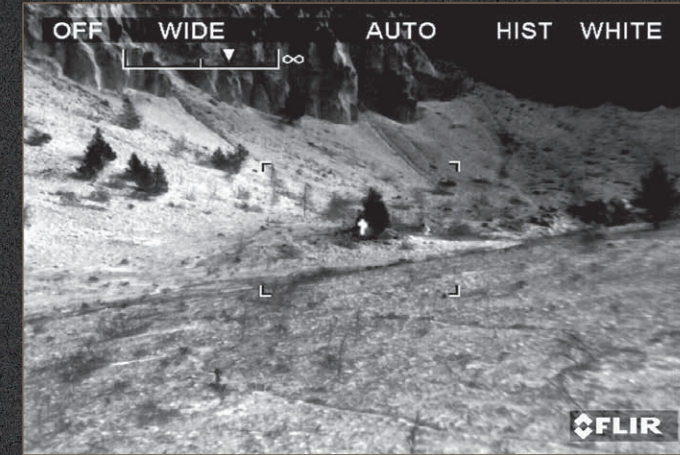

See in the dark

Because everything generates heat, thermal security cameras can see as well at night as they can during the day. Cameras dependent on visible light are useless at night or in poor visibility without supplementary illumination from lights or lasers.



Complement your visible light cameras

Low-cost infrared illuminated cameras rely on shortwave IR lamps to illuminate threats, resulting in shadows, reflections, backscatter, higher power consumption, narrow areas of illumination and much shorter ranges than passive thermal camera technology.



See through obscurants

Thermal energy passes through many obscurants including smoke, dust, modest foliage and light fog. The thermal camera can see this person clearly through the fog, but the standard visible light color camera cannot.

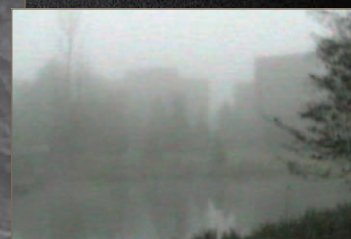

See more during the day

Conventional TV cameras rely on color contrast to provide enough information for the viewer to detect a threat. Even at moderate ranges, weak contrast can render these cameras useless. Thermal cameras don't have this limitation.



How far can you see with a thermal imager?

With thermal cameras you can clearly see anything you would see with a conventional camera, and more, day and night. But, how far can you see?

We get asked this question more than any other, and it is a reasonable one. Unfortunately, it does not have a simple answer. A thermal camera's range performance is a

combination of many factors including target size, lens focal length, and field-of-view, to name just a few.

Most applications have a lens size that will work best for them, that's why FLIR has so many cameras to choose from. Visit our website and experiment with our online field-of-view calculator to see how a man-sized target fills the screen at a given distance.



How far you can see depends on many factors including the size of the object you're looking at, and the size of the lens you're using. These three images all show people and cars from 1.25 miles away, but they look very different because they use different lenses.

Resolution matters.

When people talk about a thermal camera's resolution, they're talking about the number of pixels used to capture thermal energy. The bigger the number, the higher the camera's resolution. The higher the resolution, the more

pixels you have gathering energy. This means that a higher resolution camera will typically let you see more detail, see smaller objects, and see them from farther away, even with a wider field of view.

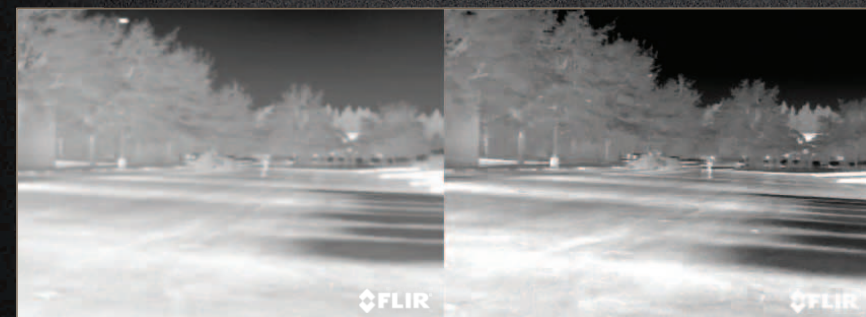

The 320 resolution image on the left shows less image detail than the 640 resolution image on the right. You can use fewer 640 cameras to cover the same amount of area, and still see farther than with 320 cameras.

With thermal cameras, images matter.

The simple fact is: not all thermal security cameras are created equal. Simply comparing manufacturer's specification sheets won't give

you the information you need to get the most effective imagers for you money. In the end, it all comes down to image quality.



Of these images, the one on the left was taken by a FLIR F-324, which uses a Vanadium Oxide (VOx) detector. The one on the right was taken with a competitor's product that uses an Amorphous Silicon detector. Both images were taken at 6pm at the end of a sunny day, but the FLIR image has greater contrast, shows more small details (note the areas outlined in red), and is in focus throughout the entire depth of the image.



This set of images is even more dramatic. They were taken at midnight when things had become more uniformly cool. Again, FLIR's VOx detector maintains its image contrast and detail, while the Amorphous Silicon detector has suffered noticeably on both counts producing a flat, washed-out image.



But just using a VOx detector isn't enough to ensure you get the best image quality. Without FLIR's proprietary Automated Contrast Enhancement image processing, even a VOx detector will give you a soft, low-detail image when improperly adjusted (right). Compare that to the FLIR image on the left and the difference is clear.

The details matter, especially the details in the image. Make sure you're getting what you need.

Fixed Cameras

Fixed-site thermal security cameras give you high-performance thermal imaging in ruggedized, all-weather enclosures. They are easy to install, simple to integrate, and are compatible with a wide variety of third-party accessories. FLIR's fixed thermal cameras are available in a choice of resolutions and come with a wide range of lenses, so you're sure to find a camera to

meet your range performance and coverage requirements. The models with full 640 x 480 thermal resolution will give you greater image detail, more extensive coverage, and better analytics performance than any other resolution, so you can do more with less.



SR-Series (analog only)

Your most affordable option for thermal night vision, SR-Series cameras are the most popular thermal security cameras in the world. With more SR-Series cameras installed around the world than any other commercial camera, you know you can trust SR-Series to perform for you today and tomorrow. SR-Series cameras give you:

- Sun-safe VOx uncooled thermal sensor technology; looking directly at the sun won't damage FLIR uncooled thermal security cameras
- Superior thermal imaging across the widest range of weather and scene conditions
- Analog video output (NTSC or PAL)
- Serial command and control
- Easy power-in, video-out integration without the need for complex set-up or configuration
- Sophisticated control interface available to operators who need advanced control options

Specifications

Array Format (NTSC)
Effective Resolution
Field Of View

Zoom

Composite Video

Weight

Dimensions (L,W,H)

Input Voltage
Power Consumption
(Consult product manuals for details of power requirements)

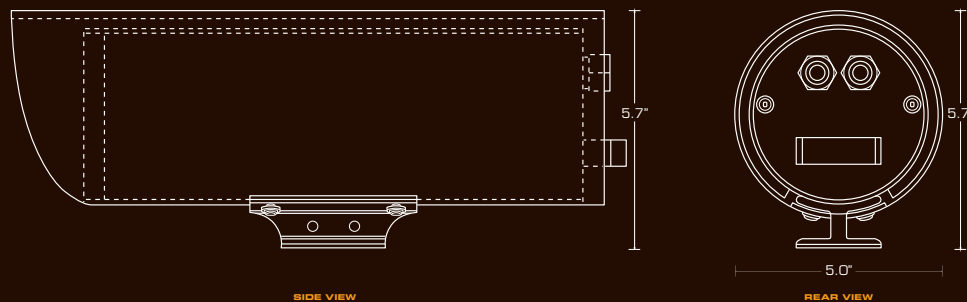

Visit flir.com/SRseries for more information.

F-Series (analog and IP)

Advanced F-Series cameras provide the same thermal imaging power as SR-Series cameras, but with expanded IP capability and field-upgradability. With F-Series you get:

- Sun-safe VOx uncooled thermal sensor technology; looking directly at the sun won't damage FLIR uncooled thermal security cameras
- Simultaneous IP and analog (NTSC or PAL) video outputs
- IP and serial control interfaces for easy integration into IP or analog networks; use F-Series in an existing analog environment and migrate easily to a future IP network
- Exchangeable camera cassettes allow for quick upgrade or repair of sensors and optics
- Open IP standards for plug-and-play integration; ONVIF compliant
- Streaming digital video available in H.264, MPEG-4, or M-JPEG formats
- Auto Digital Detail Enhancement (DDE) for optimal image quality



Specifications

Array Format (NTSC)
Effective Resolution
Field Of View

Zoom

Video over Ethernet

Weight
Dimensions (L,W,H)

Input Voltage

Power Consumption
(Consult product manuals for details of power requirements)

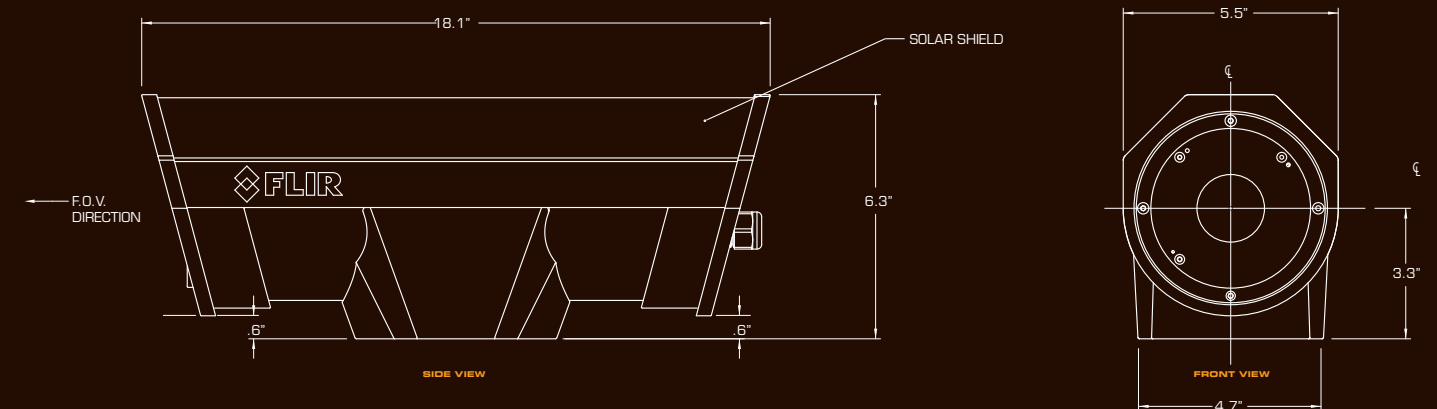

Visit flir.com/Fseries for more information.

Dome and Pan/Tilt Cameras

Pan/tilt cameras combine the power of FLIR's thermal imaging with daylight or low-light cameras in your choice of a rugged pan/tilt platform or a weatherized outdoor dome enclosure. Like FLIR's line of fixed cameras, dome and pan/tilt cameras are easy to install, simple to integrate, and are compatible with a wide variety of third-party accessories. They're also available in

a range of thermal resolutions and come with a wide variety of lenses, to give you the range performance and coverage you need. As with fixed cameras, dome and pan/tilt cameras with full 640 x 480 thermal resolution give you greater image detail, more extensive coverage, and better analytics performance than any other resolution, so you can do more with less.



D-Series

The D-Series outdoor dome enclosure provides precision pan/tilt control of the included thermal and daylight/low-light visual cameras. D-Series cameras give you:

- Sun-safe VOx uncooled thermal sensor technology; looking directly at the sun won't damage FLIR uncooled thermal security cameras
- Fully programmable scan patterns, radar slew-to-cue, and slew-to-alarm functions
- Thermal imager with either 640 x 480 or 320 x 240 resolution
- Daylight/low-light 36x zoom color CCD camera
- Simultaneous visible and thermal video outputs
- Simultaneous IP and analog (NTSC or PAL) video outputs
- Open IP standards for plug-and-play integration
- Multiple channels of streaming digital video available in H.264, MPEG-4, or M-JPEG formats
- Auto Digital Detail Enhancement (DDE) for optimal image quality

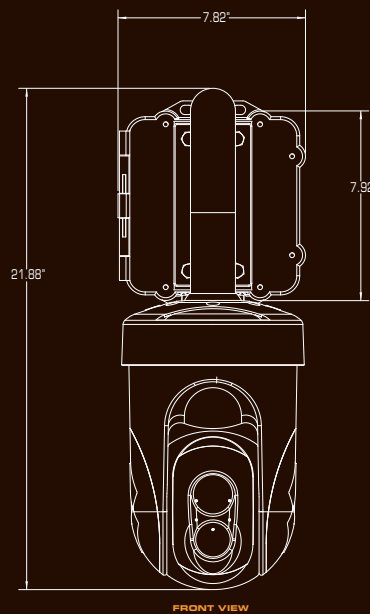
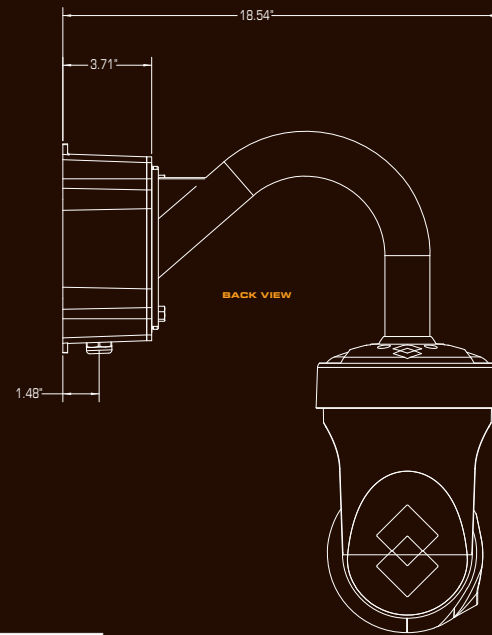

Specifications

Array Format (NTSC)			
Effective Resolution			
Field Of View			
Zoom			
Video over Ethernet			
Pan/Tilt Performance			
Pan Angle/Speed			
Tilt Angle/Speed			
Programmable presets			
Weight			
Dimensions (L,W,H)			
Input Voltage			
Power Consumption (Consult product manuals for details of power requirements)			
Visible Light Camera			
Sensor Type			
Lens			
Field of View			
Focal Length			
Zoom			
F/#			
Effective pixels (NTSC)			

Visit flir.com/Dseries for more information.

PT-Series

The PT-Series of high-performance, multi-sensor pan/tilt cameras bring thermal and visible-light imaging together in a system that gives you video and control over both IP and analog networks. The precision pan/tilt mechanism gives you accurate pointing control along with:

- Sun-safe VOx uncooled thermal sensor technology; looking directly at the sun won't damage FLIR uncooled thermal security cameras
- Fully programmable scan patterns, radar slew-to-cue, and slew-to-alarm functions
- Simultaneous IP and analog (NTSC or PAL) video outputs – thermal and visible-light – along with IP and serial control interfaces for easy integration into IP or analog networks; use them in an existing analog environment, and migrate easily to a future IP network
- Exchangeable camera cassettes allow for quick upgrade or repair of sensors and optics
- Open IP standards for plug-and-play integration
- Streaming digital video available in H.264, MPEG-4, or M-JPEG formats

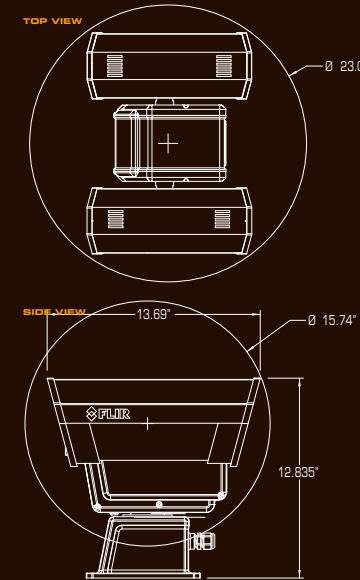
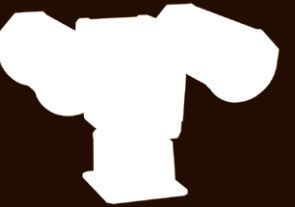

Specifications

Array Format (NTSC)			
Effective Resolution			
Field Of View			
Zoom			
Video over Ethernet			
Pan/Tilt Performance			
Pan Angle/Speed			
Tilt Angle/Speed			
Programmable presets			
Weight			
Dimensions (L,W,H)			
Input Voltage			
Power Consumption (Consult product manuals for details of power requirements)			
Visible Light Camera			
Sensor Type			
Lens			
Field of View			
Focal Length			
Zoom			
F/#			
Effective pixels (NTSC)			

Visit flir.com/PTseries for more information.

Long-Range Cooled Cameras

FLIR's high-resolution, cooled thermal security cameras provide TV-quality thermal video for long-range, 24/7 video security applications. Because they use cooled, midwave infrared detectors with 640 x 480 resolution, these cameras can detect small targets from extreme ranges, making them the perfect solutions for applications with long perimeters -

especially perimeters that can't be physically secured - and in situations that need as much warning of potential intrusion as possible. That's why FLIR's uncooled cameras are the systems of choice for border security, port and coastal security, and offshore security around the world.

HRC

Flexible enough to provide both wide area coverage and long-range, high magnification performance, HRC provides a continuous zoom thermal optical telescope with 12.5:1 zoom ratio and a variety of optical packages.

Security operators can field HRC thermal security cameras as portable, stand-alone thermal video cameras, multi-sensor surveillance suites with long-range video camera and laser rangefinder on a pan/tilt mechanism, or integrate multiple sensor systems into a long-range, day/night video security network. HRC cameras give you:

- Continuous optical & digital zoom for long reach without losing sight of intruders while zooming
- Unmatched image quality with FLIR's proprietary Tunable Digital Detail Enhancement (DDE)
- Long-range visible light camera, and daylight/low-light camera options
- Network ready installation with FLIR's JPC module
- Serial control
- Composite video output for use with video management and display systems
- Threat geo-location capable with built-in DMC, GPS, and LRF (MS configuration)

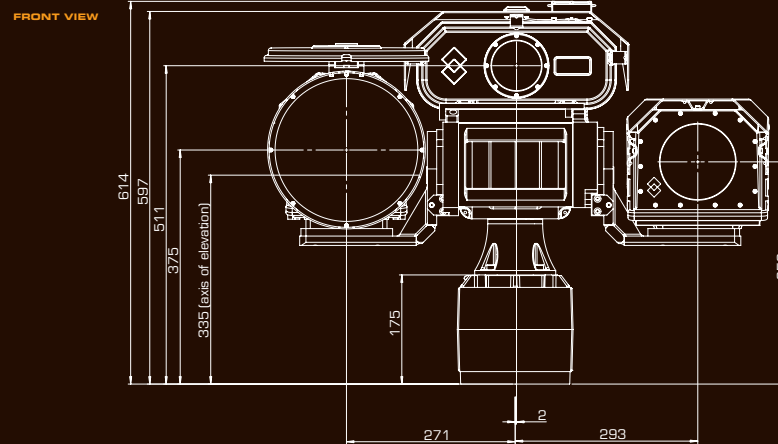
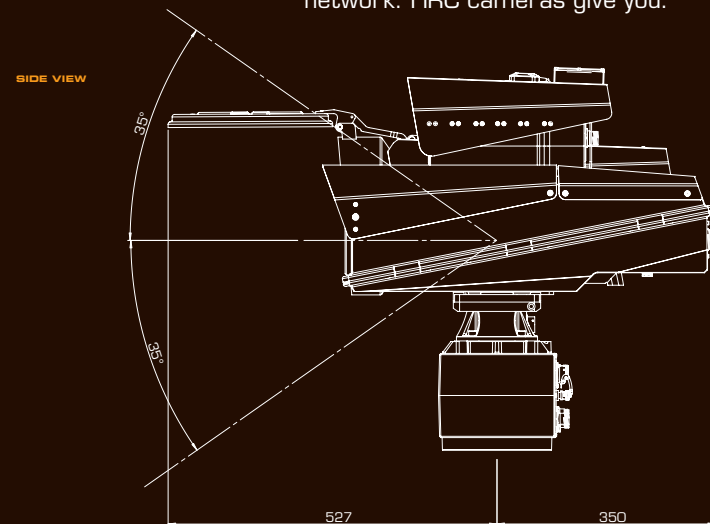

PT-602CZ

The new PT-602CZ creates sharp thermal images of small details in challenging conditions and at long ranges. Equipped with powerful continuous zoom optics that combine excellent situational awareness with impressive zoom capability, the PT-602CZ is a flexible imaging solution for the most demanding applications.

The PT-602CZ brings a new level of performance to the popular PT-Series of thermal security cameras:

- Improved threat detection and alarm assessment capabilities
- Long-range threat detection - detect a person from over 5.5 miles away
- Continuous zoom so you can zoom in on targets without losing sight of them
- Autofocus keeps your images sharp when changing zoom
- Precision pan/tilt mechanism that is ready for radar integration and slew-to-cue operation

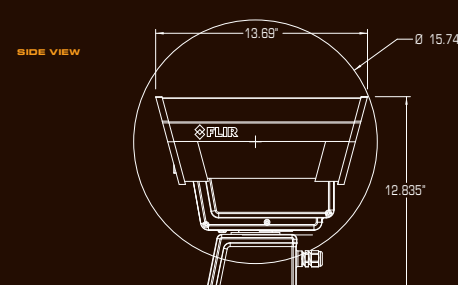
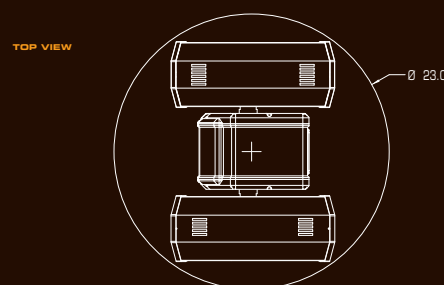

Specifications

- Array Format (NTSC)
- Detector Type
- Spectral Range
- Field Of View
- Zoom
- Composite Video NTSC or PAL
- Video over Ethernet
- Pan Angle/Speed
- Tilt Angle/Speed
- Programmable presets
- Weight
- Dimensions (L,W,H)
- Input Voltage
- Power Consumption (Consult product manuals for details of power requirements)
- Sensor Type
- Lens Field of View
- Focal Length
- Zoom
- F/#
- Effective pixels (NTSC)

Specifications

- Array Format (NTSC)
- Effective Resolution
- Field Of View Limits (Continuous Zoom)
- Video over Ethernet
- Pan Angle/Speed
- Tilt Angle/Speed
- Programmable presets
- Weight
- Dimensions (L,W,H)
- Input Voltage
- Power Consumption (Consult product manuals for details of power requirements)
- Sensor Type
- Lens Field of View
- Focal Length
- Zoom
- F/#
- Effective pixels (NTSC)

Handheld Thermal Cameras

FLIR's Guardsman handheld thermal imaging cameras let security professionals see clearly in total darkness, providing an undeniable tactical advantage. Using the same technology popular with law enforcement and military units around the world, Guardsman provides the information people need to maximize operational effectiveness, respond quickly, and stay safe.

Thermal Analytics Processor

By combining our thermal security cameras with the Thermal Analytics Processor, we've created the first all-in-one solution to join thermal night vision with edge NVR storage, IP video encoding, and adaptive analytics optimized for FLIR's range of high-performance thermal cameras.



Scout PS

The Scout cameras are the most affordable, full resolution handheld cameras around, and put the power of every security pro's hand. Rugged, compact, and easy to use, Scout gives you go-anywhere thermal night vision whenever and wherever you need it.

Guardsman

Guardsman's thermal imaging core provides four times the image clarity and detail of earlier systems, allowing security officers to see more of their surroundings than any other night vision technology in the world. FLIR's advanced image-processing algorithms produce, crisp, clear thermal video day and night, in good weather and bad.

Guardsman offers both grey scale and color thermal imaging, and can display a digital temperature readout of the object in the center of the scene. Best of all, Guardsman is the first full-featured personal thermal imaging camera affordable enough for every member of the security team to have the unsurpassed advantages that come with full-resolution thermal night vision.

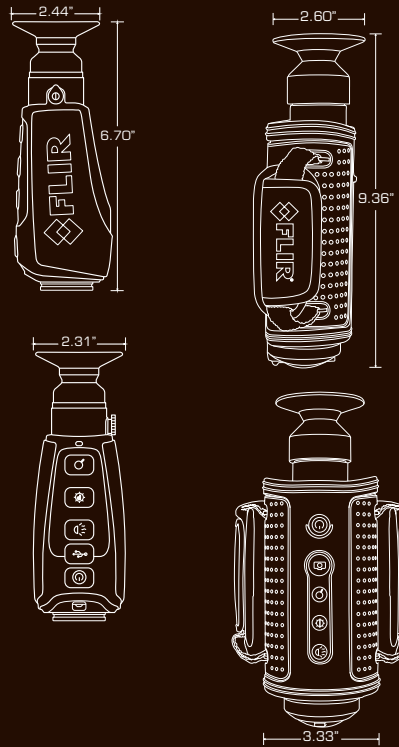

Specifications

Detector Type

Focal Length
Field of View (H x W)
Waveband
Digital E-Zoom
Start-up
Diopter Adjustment
USB Port
Tasklight

Built-In Viewfinder Display
Polarity / Detection Palettes
Image Optimization
Video Output

Weight (with battery)
Size (L x W x H)
Fixed Use

Battery Type, Operating Time
Battery Recharging

Rating
Operating Temp.
Handheld Package Includes:

Optional Accessories

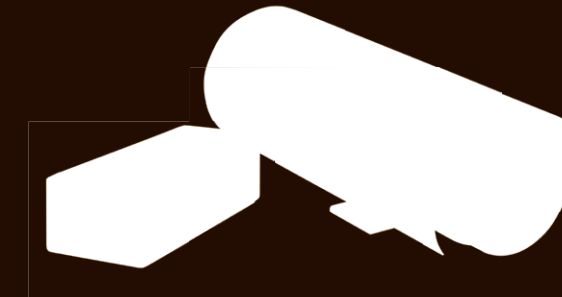

24/7 Video Intrusion Detection for Automated Perimeter Security.

Pre-integrated with many common enterprise Video Management Software products including, Milestone, Genetec, OnSSI, and Lenel, this is the most effective, affordable off-the-shelf solution available for thermal security.

The Thermal Analytics Processing System features adaptive analytics algorithms that are specially designed to work with FLIR thermal video, virtually eliminating nuisance alarms so you can respond more efficiently and cost-effectively.

The Thermal Analytics Processing System features:

- Self-calibrating, Adaptive Video Analytics specially tuned for FLIR thermal video
- Classifies objects as people, automobiles, or boats and only alarms on the classified threats you specify – not just on video motion
- Adaptive Analytics that work on all video resolutions including megapixel, not just 320 x 240 like most other analytics

- Self-calibrating analytics that require little or no set-up
- Flexible installation for "edge based" or "central server based" architecture
- Visual Alarm presentation; unique colored box around objects based on classification
- Analytic behaviors that include fence-line perimeter crossing, area alert, direction of travel alert, crowd detection, and more.
- Zero Bandwidth "edge" recording
- Your choice of 160 GB or 500 GB on-board hard drive for weeks of video storage
- IP video encoding: input analogue video and output H.264 compressed video at up to 30 frames per second in all resolutions

The Thermal Analytics Processor is an integral part of any initial Thermal Fence installation. For a more involved Thermal Fence – with expanded sensor integration and threat geo-location – contact your FLIR representative.

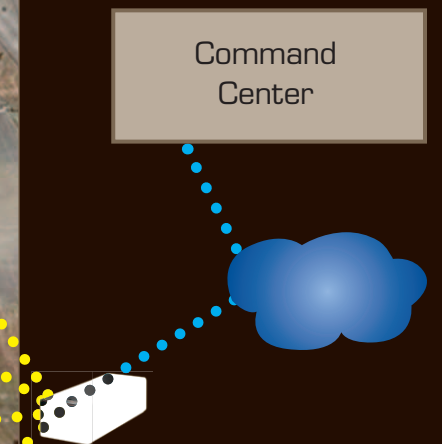

Range Chart

Uncooled Cameras

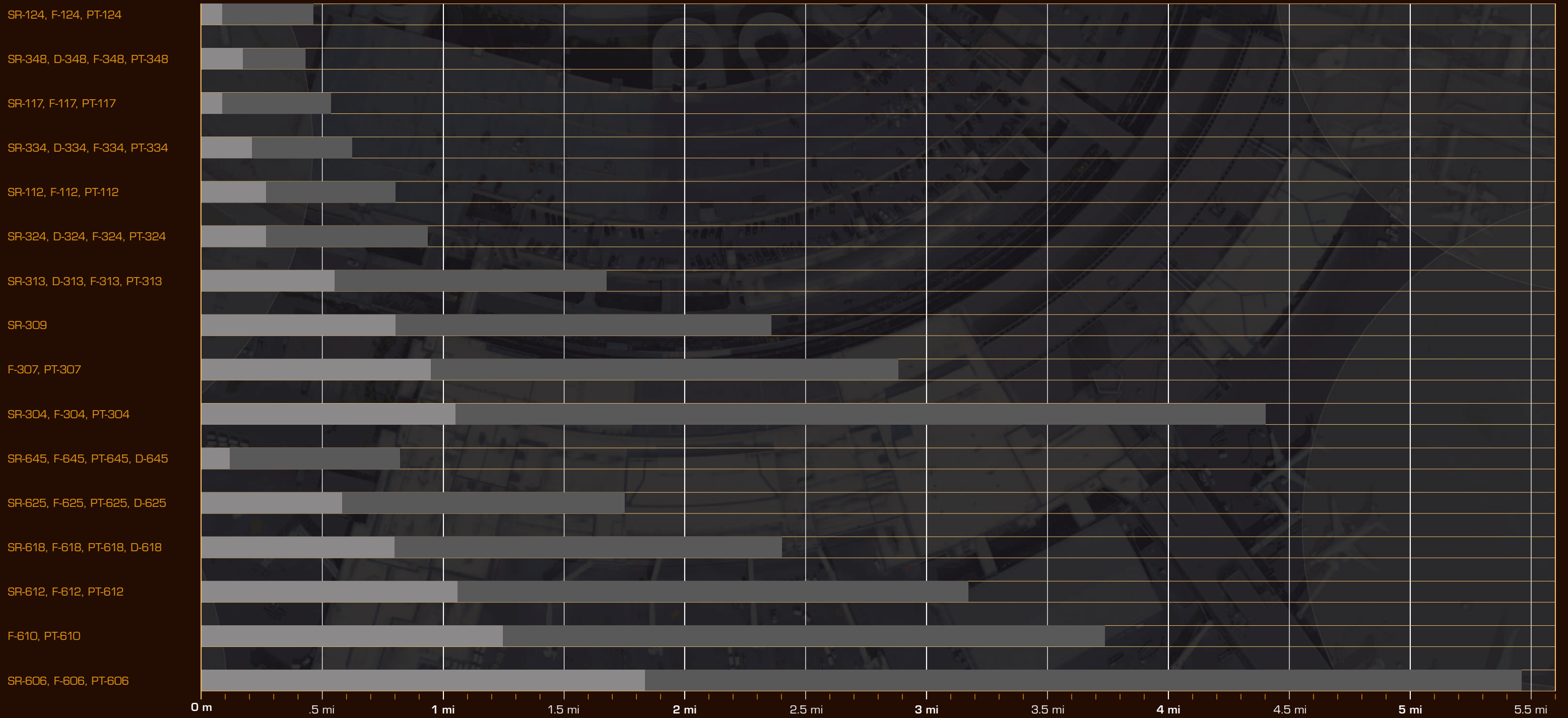
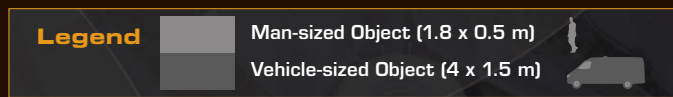

Observed performance may vary based on environmental conditions, topography, monitor setup, operator experience, camera settings, and camera configuration.

The FLIR Advantage

FLIR has more thermal cameras in the field today than all other manufacturers combined. The one thermal imaging company with the combination of expertise, product offerings, and experience to bring you military-grade thermal imaging at commercial prices, only FLIR combines high performance with low risk.

The Experts in Thermal Imaging

FLIR designs, builds, and integrates all of the camera's vital components – from the detector to the image processing software. We're the only company with the expertise to give you every last bit of imaging performance, so you can see more and see farther than ever. FLIR takes the thermal technologies it designs for the battlefield and commercializes them for industrial use; no other supplier offers FLIR's range of combat-proven thermal technologies at commercial prices.

Tough Products Built to Last

For lots of companies, being able to offer the most extensive range of camera resolutions, lenses, and configurations on the market would be a triumph. Not at FLIR. We need to know that our cameras are tough enough to last, so we make sure our security cameras exceed industry standards for electronic surge protection, shock, and vibration resistance. You can be confident that your FLIR cameras will be covering your perimeter for years to come.

10-Year Detector Warranty

FLIR is the only manufacturer confident enough to cover the most vital element of its uncooled cameras – the infrared detector itself – for a full 10 years, and the entire camera system for up to three years. Ask your FLIR representative for all of the details.

Performance, durability, and support you can count on.

That's The FLIR Advantage.



PORTLAND
Corporate Headquarters
FLIR Systems, Inc.
27700 SW Parkway Ave.
Wilsonville, OR 97070
USA
PH: +1 877.773.3547
PH: +1 503.498.3547
FX: +1 503.498.3153

SANTA BARBARA
FLIR Systems, Inc.
70 Castilian Dr.
Goleta, CA 93117
USA
PH: +1 877.773.3547
PH: +1 805.964.9797
FX: +1 805.685.2711

BOSTON
FLIR Systems, Inc.
9 Townsend West
Nashua, NH 03063
USA
PH: +1 866.477.3687
PH: +1 603.324.7600

NETHERLANDS
FLIR Systems BV
Charles Petitweg 21
4847 NW Teteringen - Breda
The Netherlands
PH: +31 (0) 765 79 41 94
FX: +31 (0) 765 79 41 99

www.flir.com

NASDAQ: FLIR

Equipment described herein may require US Government authorization for export purposes. Diversion contrary to US law is prohibited. Imagery used for illustration purposes only.

Specifications are subject to change without notice. ©2012 FLIR Systems, Inc. All rights reserved.

Imagery used for illustration purposes only. 1011364 01/12

